

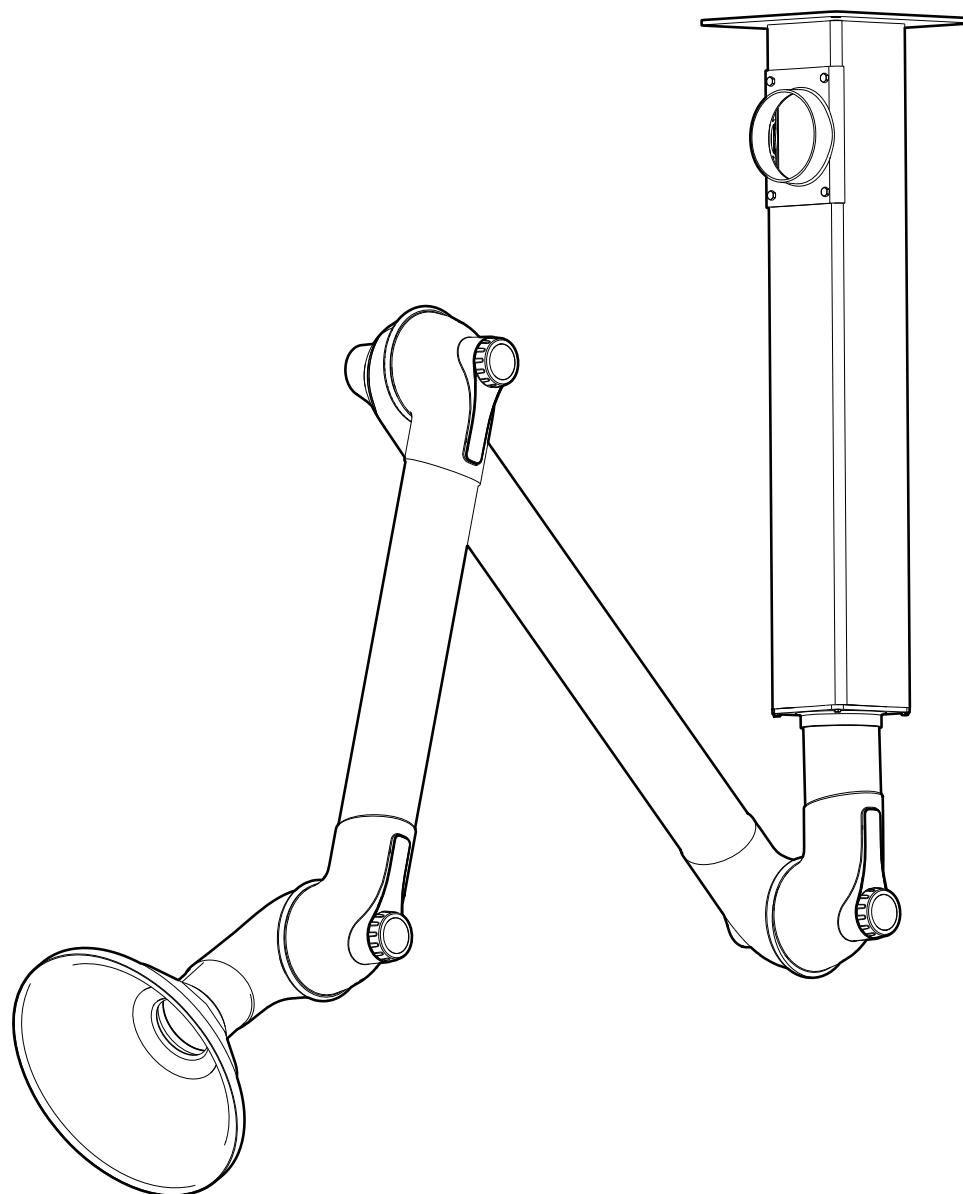

ME 50/75



ROC
ABSAUGARME

Ihre Verbindung zur reiner Luft.

PURE ADVANTAGE

1

MTI

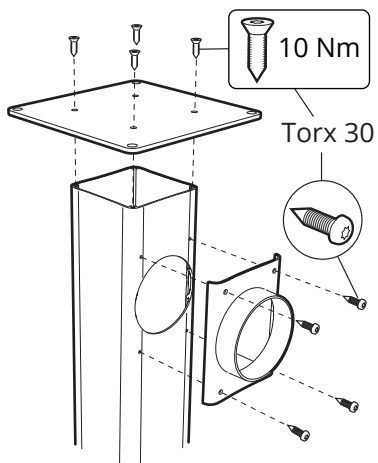

MTF

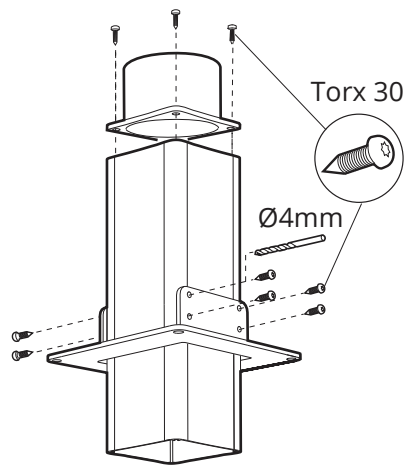

MVK

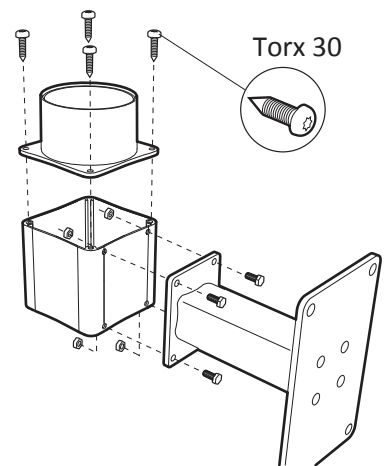

2

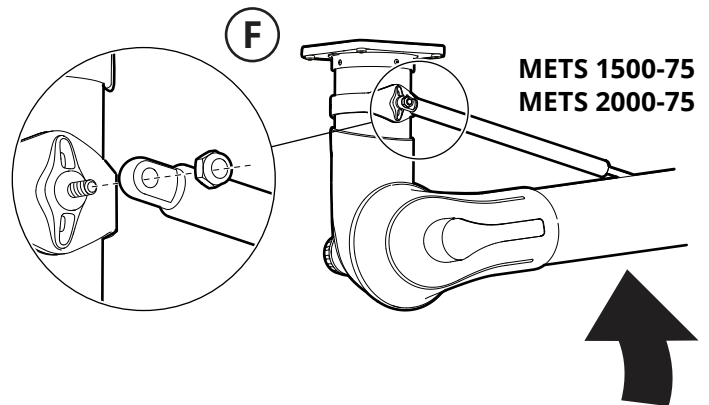
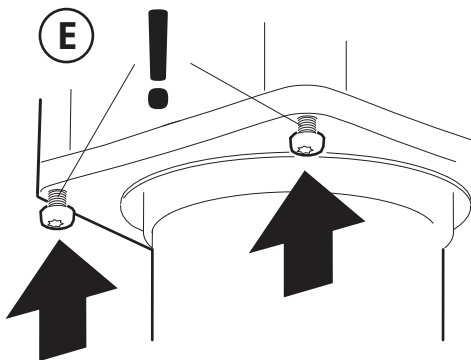
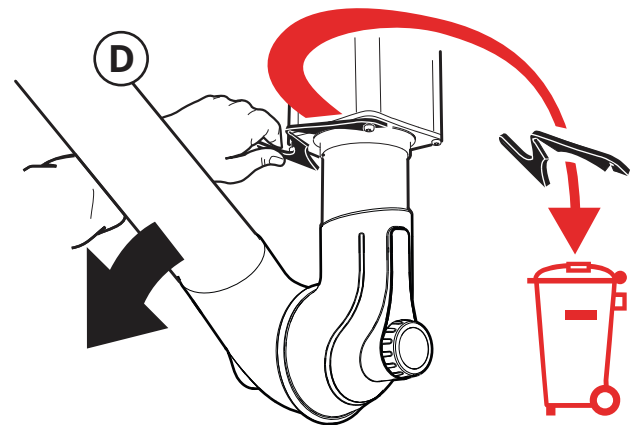
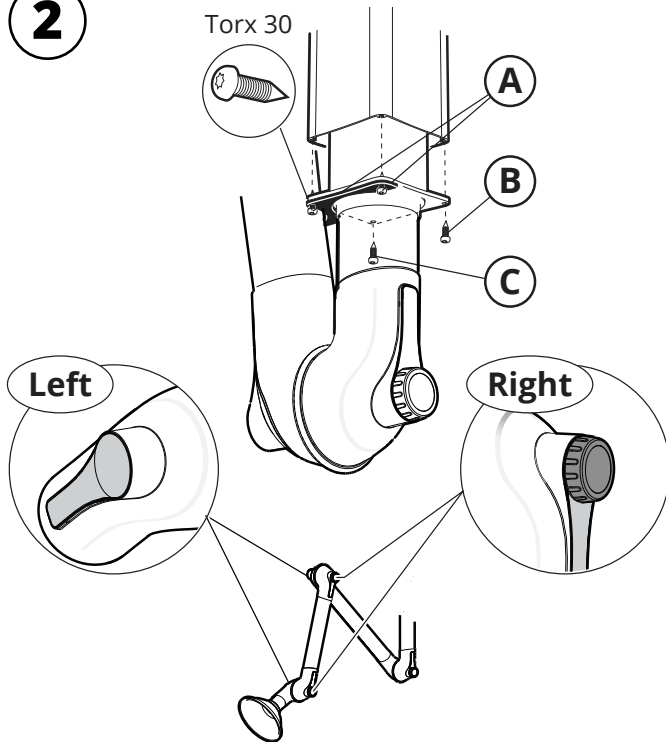

1

MEB

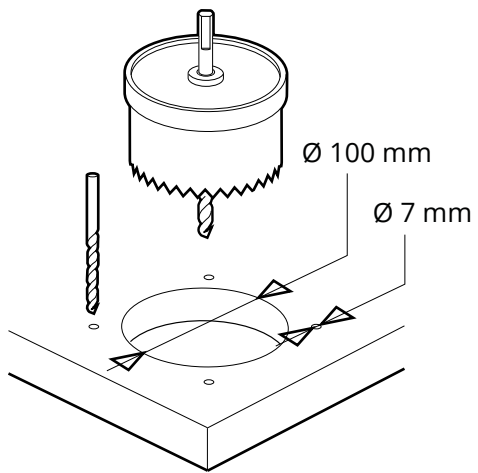

2

M6x4

M6x4

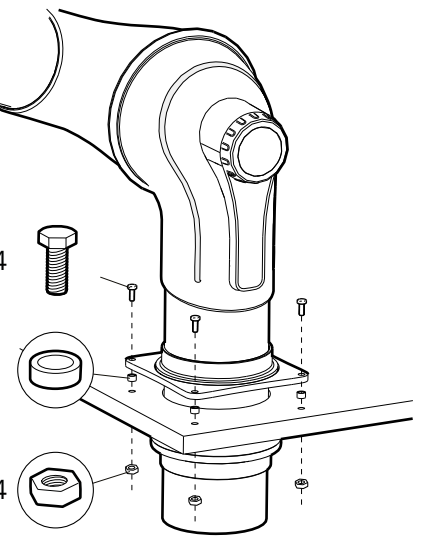

3

A

B

C

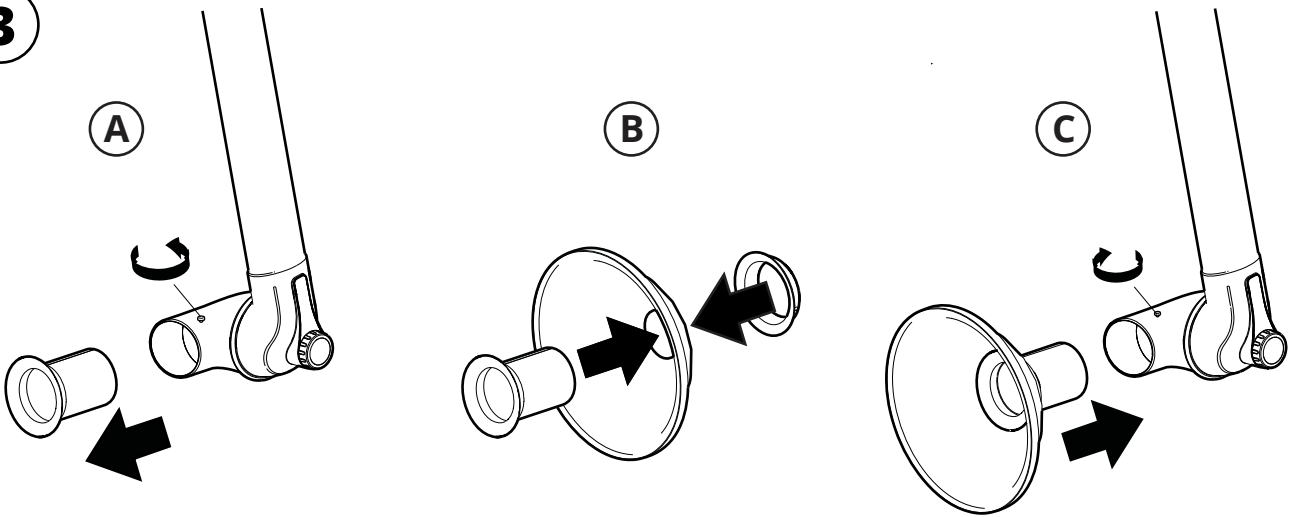

4

ESD

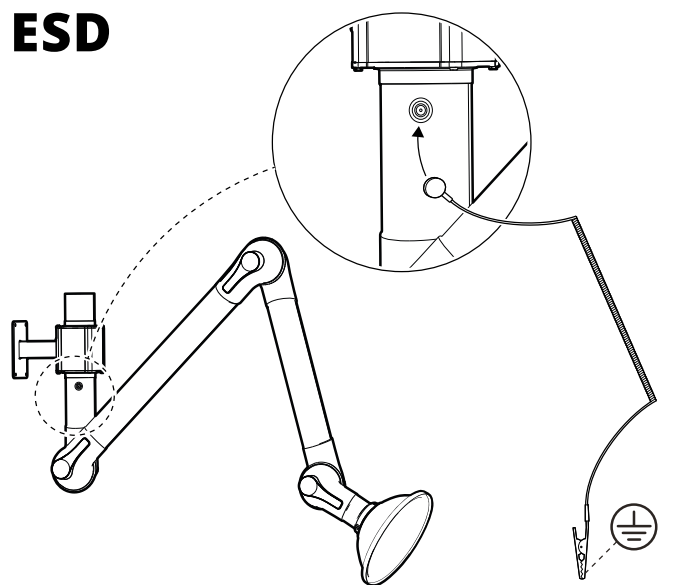
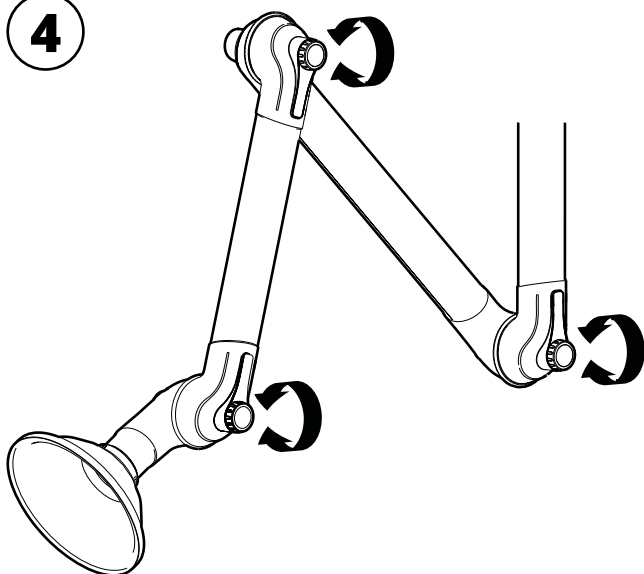

Exploded view

MTI

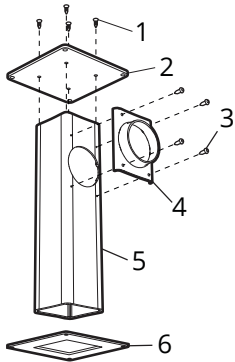

MTF

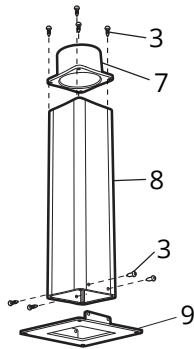

MVK

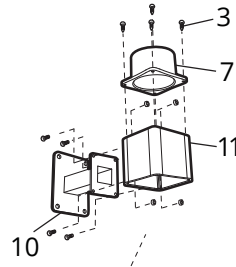

MBF

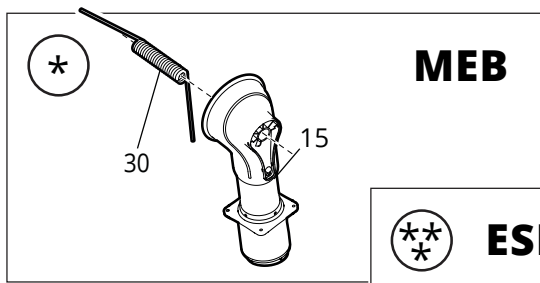
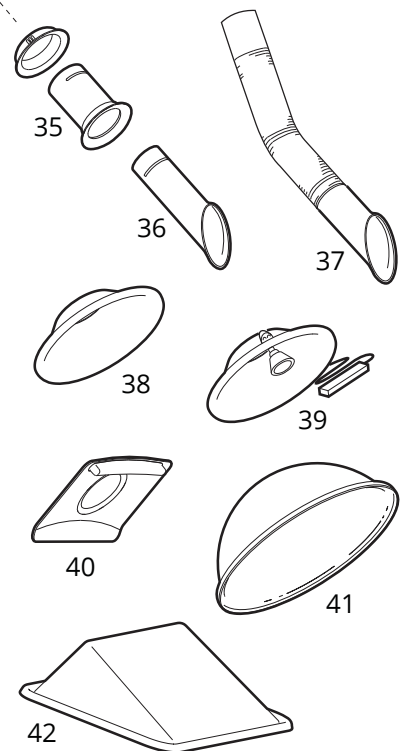
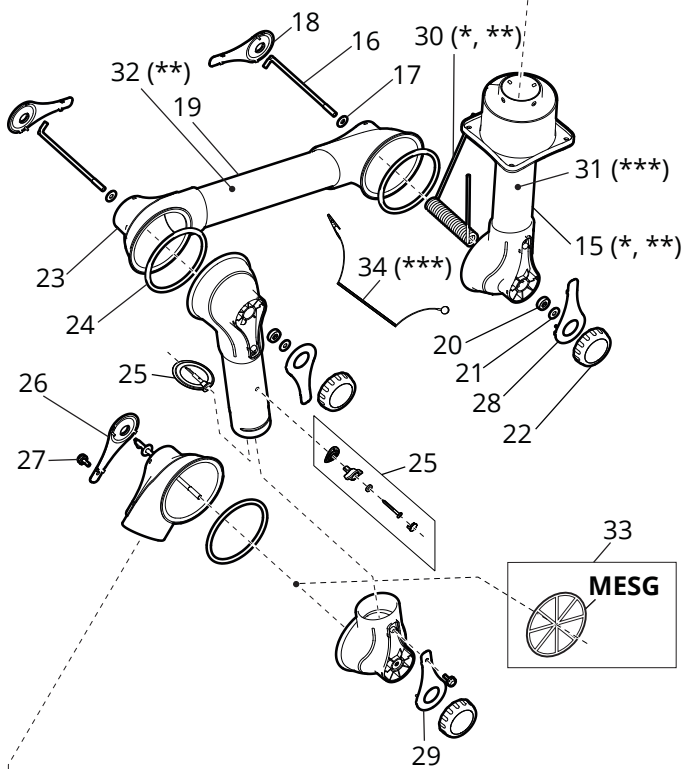
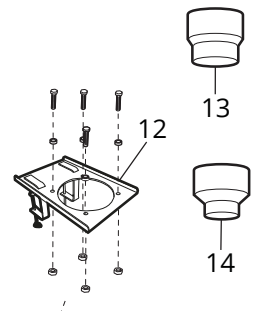

MEB

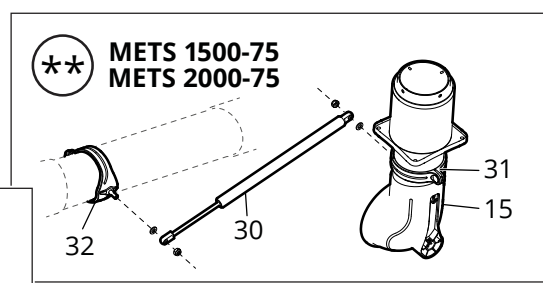

METS 1500-75
METS 2000-75

EXTRACTION ARMS · VEHICLE EXHAUST EXTRACTION · FANS · CURTAINS · CONTROLS



ROC
ABSAUGARME



ME 100

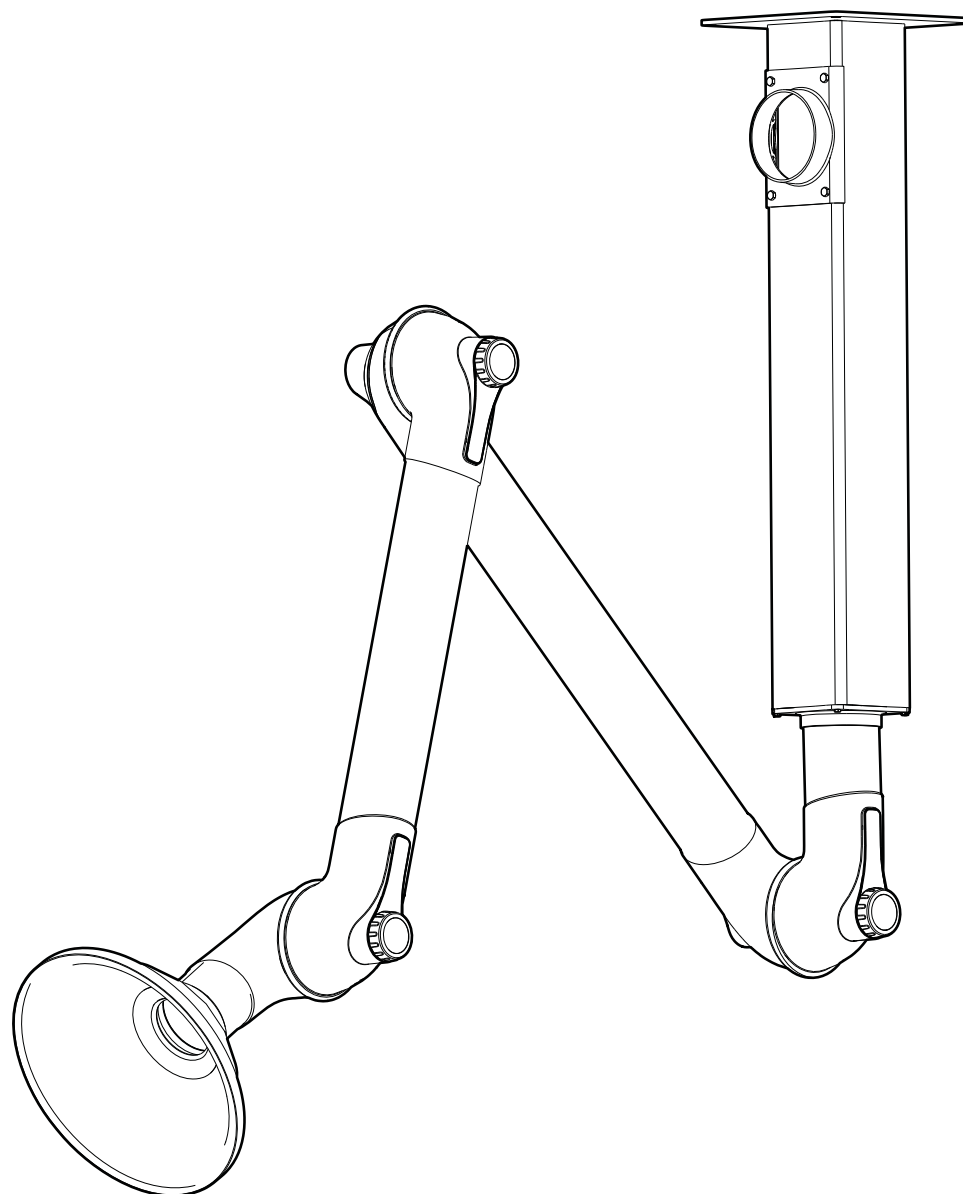

ROC
ABSAUGARME

Ihre Verbindung zur reinen Luft.

PURE ADVANTAGE

1

MTI

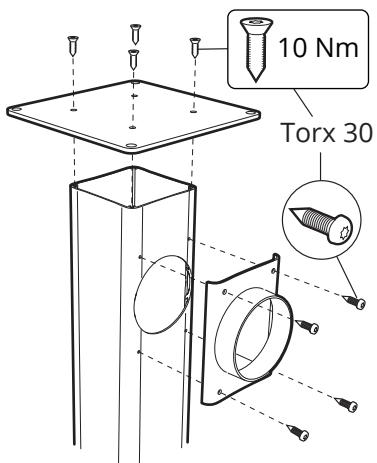

MTF

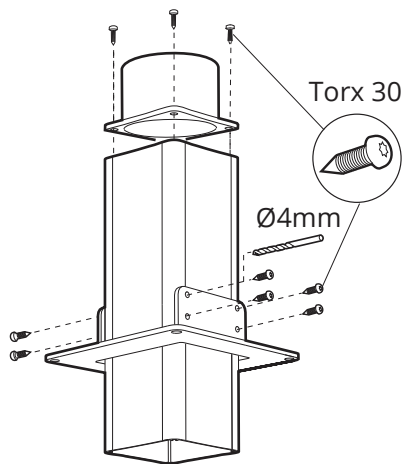

MVK

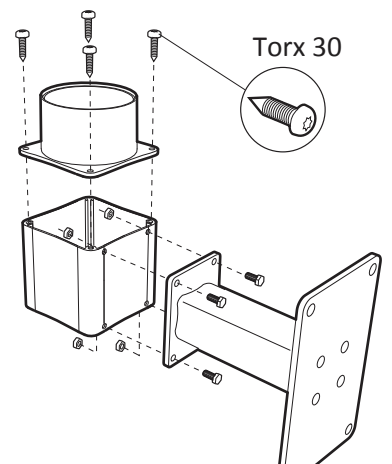

2

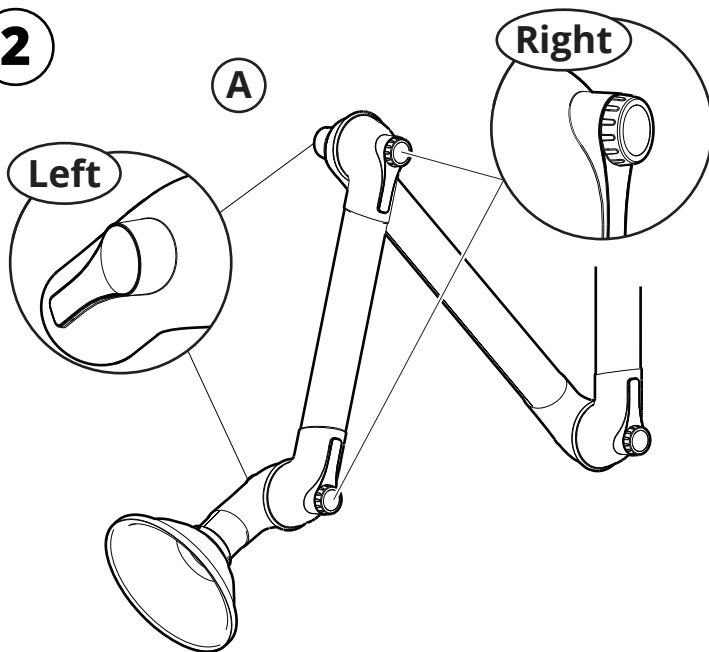

B

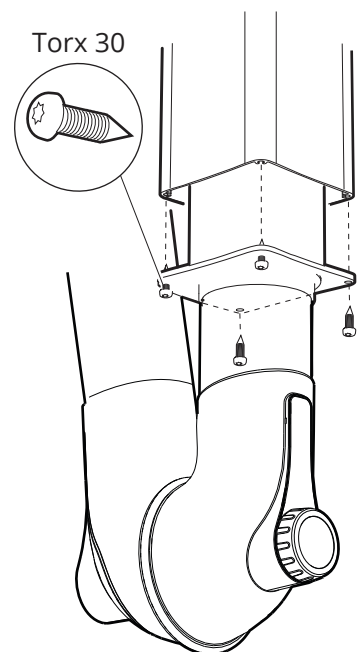

1

MEB

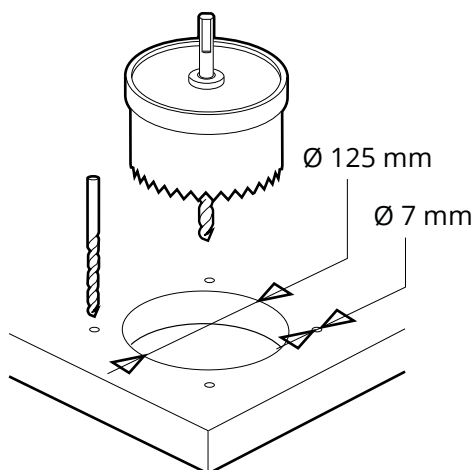

2

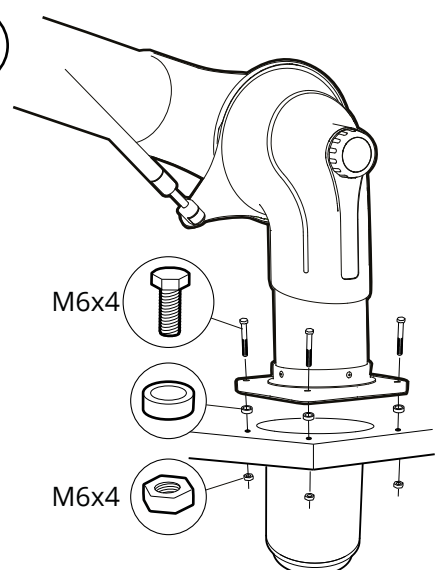

3

MET 1150-100
MET 1350-100

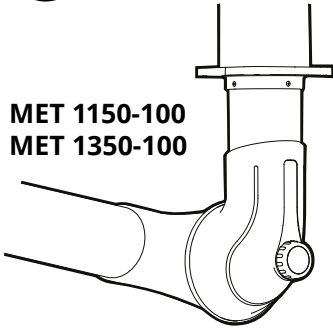

MEB 1150-100*
MEB 1350-100*
MEB 1650-100
MEB 1900-100

**No gasspring*

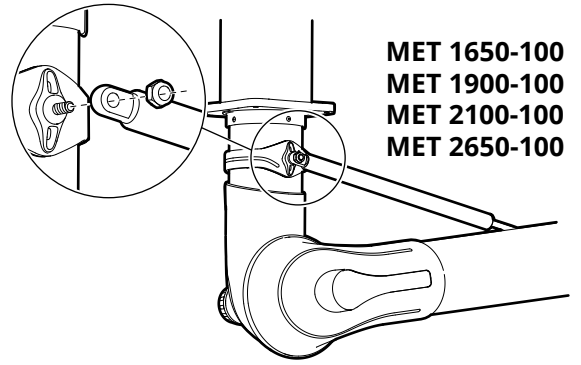
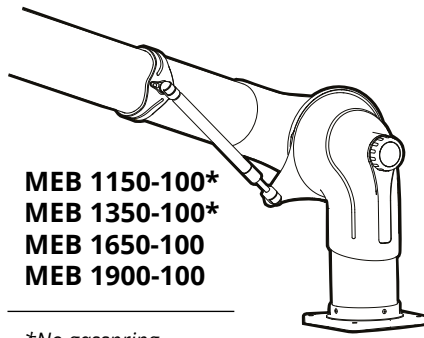

MET 1650-100
MET 1900-100
MET 2100-100
MET 2650-100

4

A

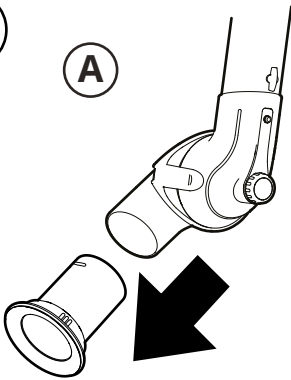

B

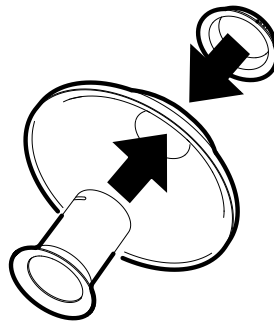

C

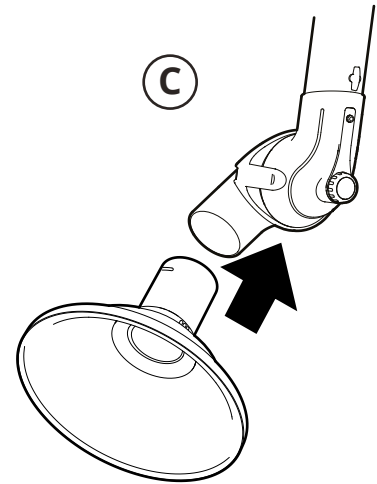

5

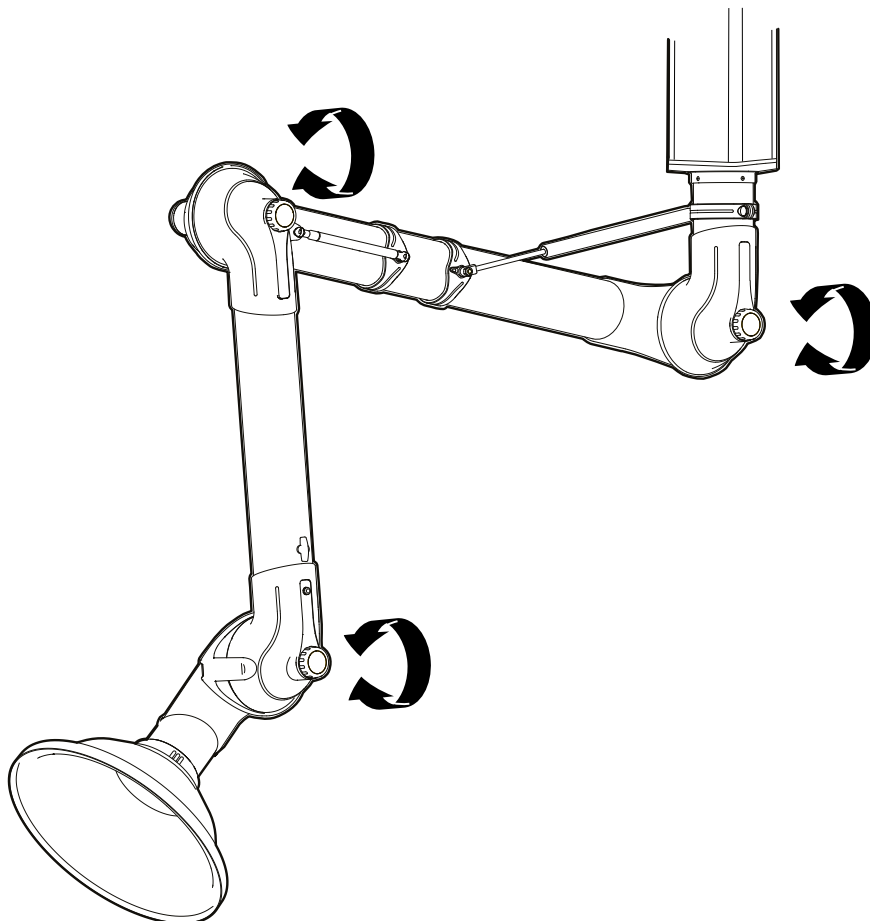

Exploded view

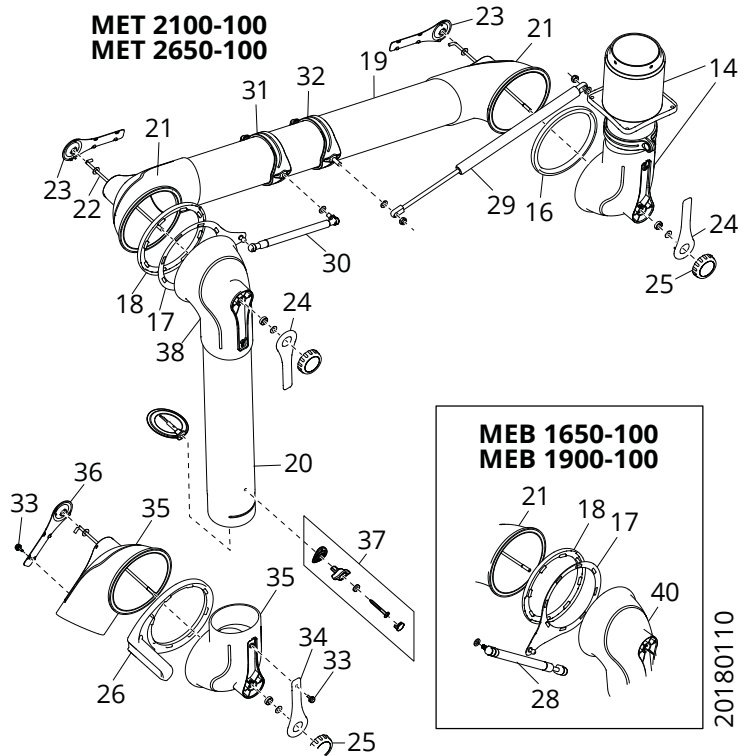
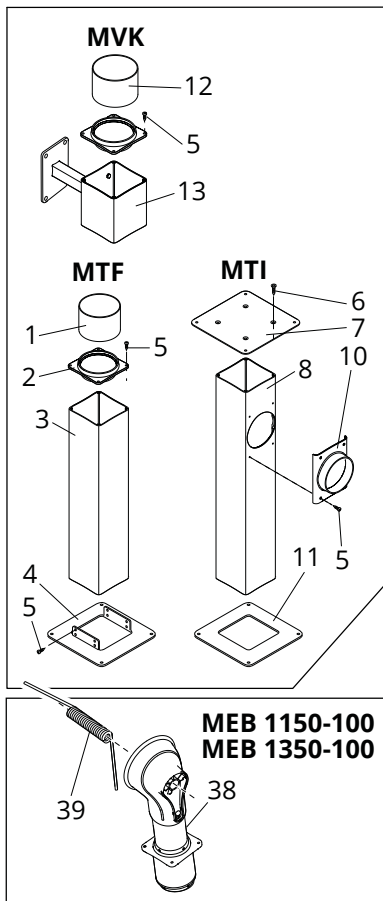
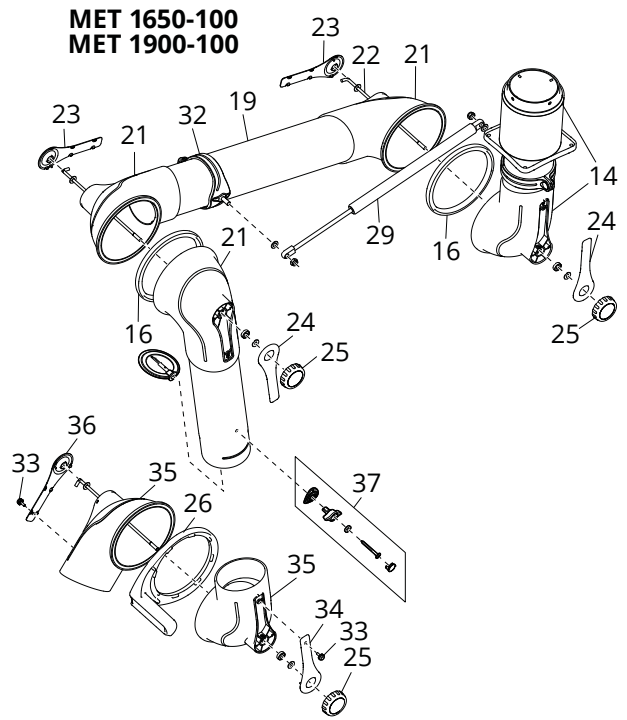
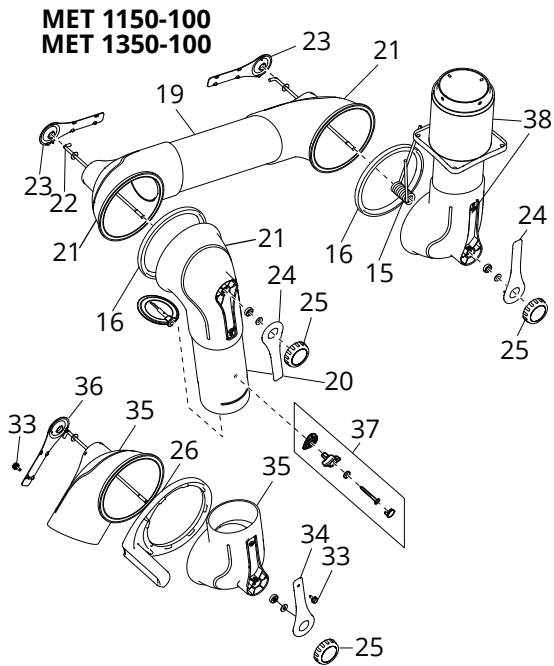

20180110

EXTRACTION ARMS · VEHICLE EXHAUST EXTRACTION · FANS · CURTAINS · CONTROLS



ROC
ABSAUGARME